



**Document 3.1- ES Volume 2  
Appendix 6.1 Greenhouse Gas  
Calculations**

**The Kemsley Mill K4 Combined Heat and  
Power Generating Station Development  
Consent Order**

**Planning Act 2008 The Infrastructure Planning  
(Applications: Prescribed Forms and  
Procedure) Regulations 2009  
Regulation 5(2)q**

**April 2018 - Submission Version**

**PINS Ref: EN010090**

## Appendix 6.1 GHG Calculations

### 6.1.1 Introduction

6.1.1.1 This appendix provides additional details of the calculation of GHG emissions impacts reported in Chapter 6 of the Environmental Statement. It sets out the boundary of the assessment, data inputs or assumptions, and the output of the calculations. It should be read together with Chapter 6, which provides the policy context, explains the with- and without-development scenarios assessed, and characterises the significance of effects due to the net change in GHG emissions attributed to the Proposed Development.

### 6.1.2 Assessment boundary

6.1.2.1 The spatial, temporal, and life-cycle stage boundaries of the assessment are shown in Diagram 6.1.1.

6.1.2.2 *De-minimis* sources are defined as those estimated to each be  $\leq 1\%$  of total GHG emissions. Further discussion of inclusions and exclusions from the defined current and future assessment scenarios is given in Chapter 6.

#### ***Allocation and attribution***

6.1.2.3 All calculated net GHG emissions within the assessment are allocated and attributed to the Proposed Development, for the purpose of assessing its net impacts. No differential allocation or attribution based on operational control, ownership or equity share has been required.

### 6.1.3 Energy supply and demand

6.1.3.1 Diagram 6.1.2 shows the assumed energy balance in the current baseline, the future baseline with operation of refurbished K1 and K3, and future with the Proposed Development. Current baseline information for K1 is drawn from operating data in 2016.

6.1.3.2 Around 29 days of shutdown for planned maintenance and other outages were recorded for K1 in 2016. Assuming these were 24-hour shutdowns, annual uptime was around 8,064 hours, or 92%. These operating hours have been used to derive energy inputs and outputs in MW for K1 in 2016.

6.1.3.3 All energy inputs and outputs, in MW, have been multiplied by the Proposed Development's expected annual uptime of 8,410 hours for consistency of comparison in the current baseline, future baseline and with-development scenarios. Backup energy supply to the Kemsley Paper Mill in the remaining hours (e.g. from package boilers) is therefore assumed not to change due to the Proposed Development and is not included in the calculation. Similarly, the operation of K2 and K3, while included in Diagram 6.1.2 to show their influence in the energy balance, would not be affected by the Proposed Development and hence GHG emissions from these sources would not change and have not been calculated.

**Construction**  
(extraction, manufacture and delivery of materials; construction activities)

Construction stage emissions are considered unlikely to be material to the total, and likely *de-minimis*. They have been estimated based on published sources, indicating a likely 1% contribution to the life-cycle total, rather than calculated: see paragraph 6.6.2 in Chapter 6.

**Exclusions**

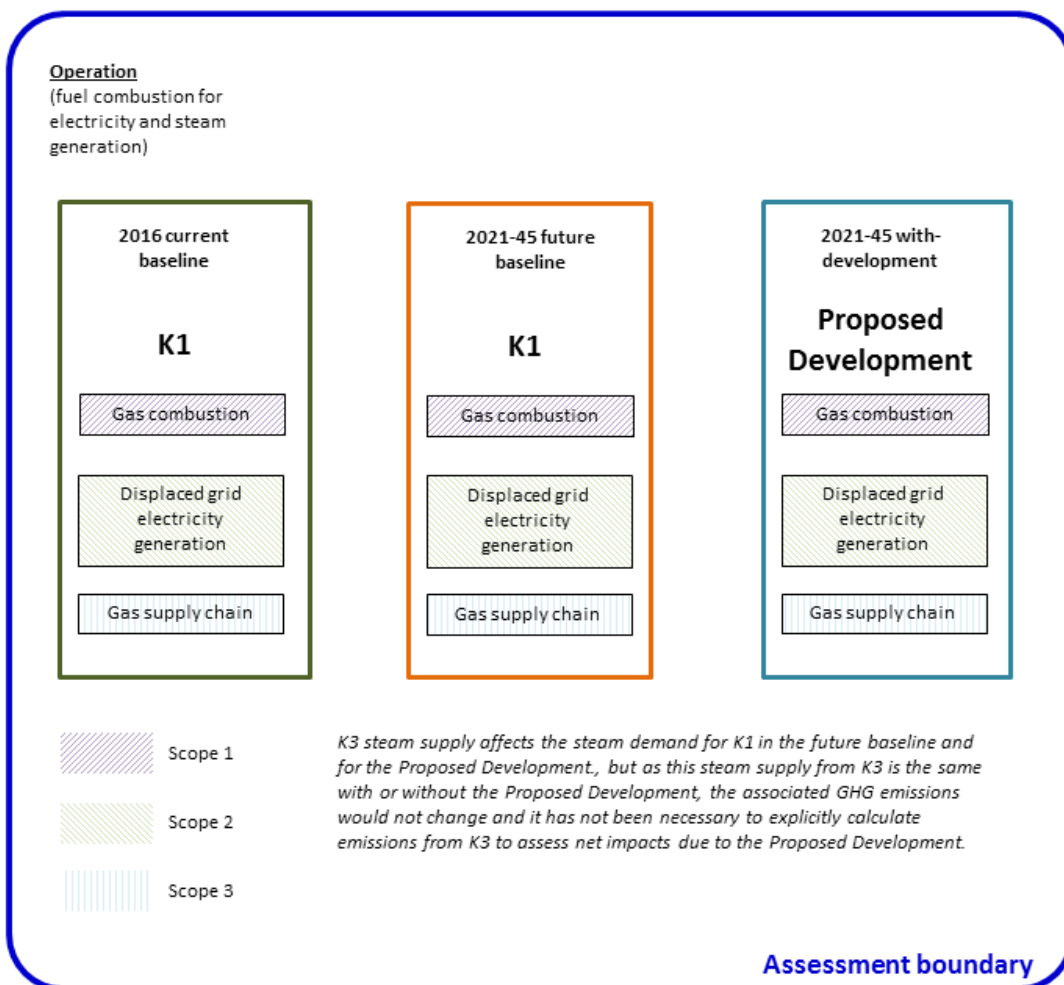

**Maintenance / refurbishment**  
(routine maintenance; component replacements or refits)

No major refit within the Proposed Development's operating lifetime is planned. Routine maintenance would have lesser emissions than construction and be *de-minimis*.

**End of life**  
(decommissioning, deconstruction, re-use or disposal of materials)

End-of-life emissions are considered very unlikely to be material to the total. See paragraphs 6.3.39 to 6.3.41 in Chapter 6.

**Exclusions**

Diagram 6.1.1: Assessment boundary

Current baseline

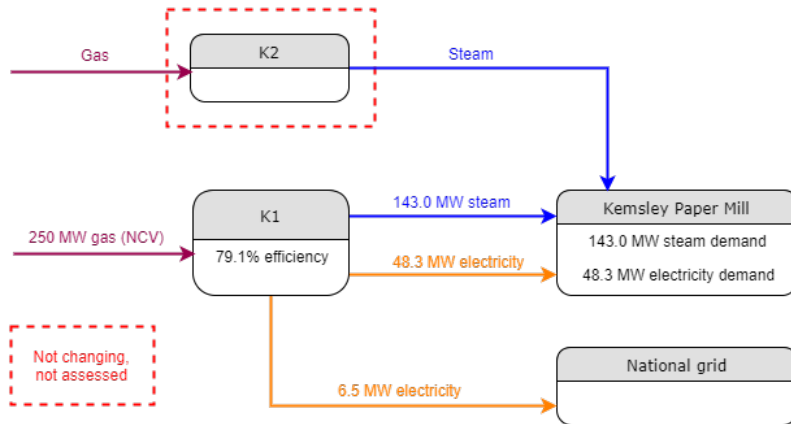

Future baseline

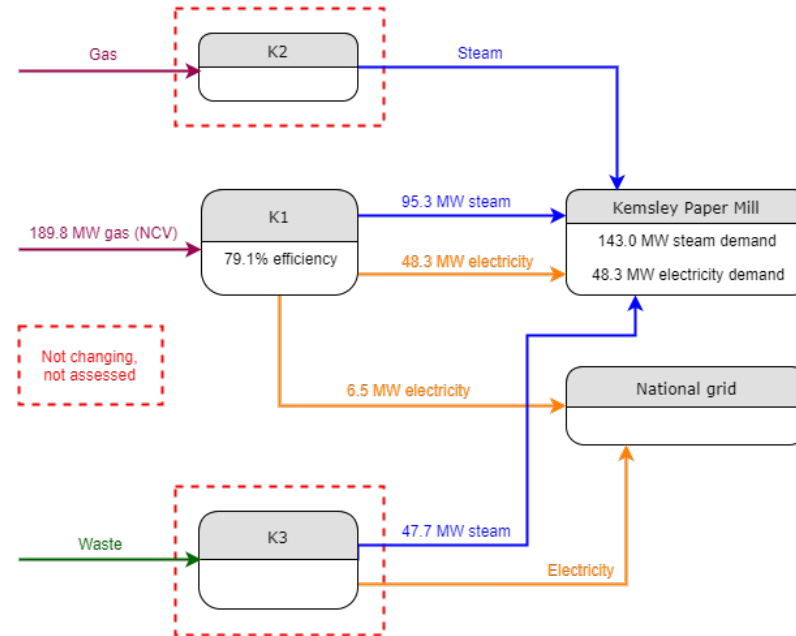

Future with Proposed Development

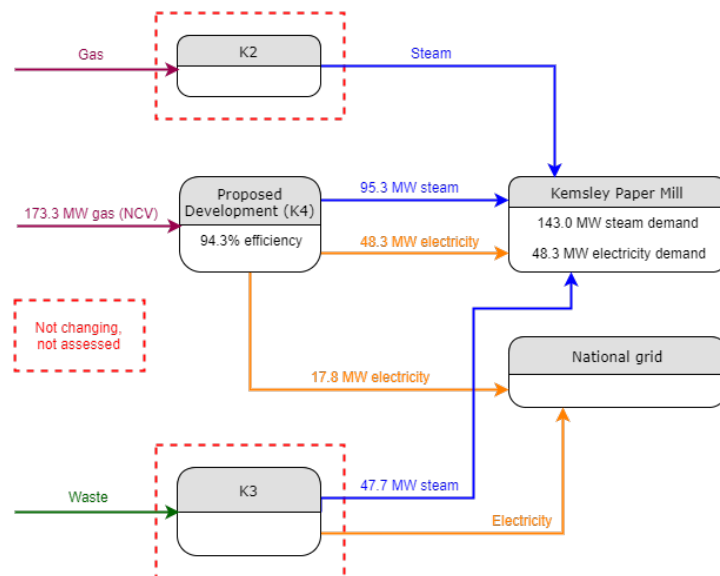

Diagram 6.1.2: Energy supply and demand assumptions

## 6.1.4 Emissions factors and data sources

6.1.4.1 Table 6.1.1 lists the emission factors, other data inputs and their sources, used in the calculations.

Parameter	Factor	Unit	Source or notes
Natural gas combustion	0.2046	kgCO <sub>2</sub> e/kWh	Scope 1 [Ref. 6.1.1]
Natural gas supply chain	0.0309	kgCO <sub>2</sub> e/kWh	Scope 3 [Ref. 6.1.1]
Marginal displaced electricity generation: 2016	0.2982	kgCO <sub>2</sub> e/kWh	As-generated, scope 2 only. [Ref. 6.1.2]
Marginal displaced electricity generation: 2021	0.2486	kgCO <sub>2</sub> e/kWh	As-generated, scope 2 only. Intervening years are shown in Table 6.1.3. [Ref. 6.1.2]
Marginal displaced electricity generation: 2045	0.0365	kgCO <sub>2</sub> e/kWh	As-generated, scope 2 only. Intervening years are shown in Table 6.1.3. [Ref. 6.1.2]
Grid-average electricity generation: 2021	0.1940	kgCO <sub>2</sub> e/kWh	As-generated, scope 2 only. [Ref. 6.1.2]
Grid-average electricity generation: 2045	0.0365	kgCO <sub>2</sub> e/kWh	As-generated, scope 2 only. [Ref. 6.1.2]
Marginal displaced electricity generation: CCGT	0.3426	kgCO <sub>2</sub> e/kWh	As-generated, scope 2 only. [Ref. 6.1.2]
K1 2016 baseline operating hours	8,064	hours	Estimated from K1 operating records.
K4 annual operating hours	8,410	hours	Design, paragraph 2.4.16 of Chapter 2.

Table 6.1.1: Emission factors and other inputs

6.1.4.2 Several minor miscellaneous other sources of GHG emissions are reported in the 2016 EU ETS return for K1 and K2, including urea consumption (assumed to be used for NO<sub>x</sub> control and leading to N<sub>2</sub>O emissions), gas oil consumption, and both the fossil and biogenic components of paper and other sludge combustion. The latter sources concern K2; the former, which may be from K1, are considered *de-minimis* at <0.05% of the gas combustion emissions and have not been assessed further.

### **Displaced electricity generation**

6.1.4.3 BEIS publishes projections of the carbon intensity of long-run marginal electricity generation and supply that would be affected by small (on a national scale) sustained changes in generation or demand [Ref. 6.1.2]. BEIS's projections over the Proposed Development's assumed operating lifetime are based on an interpolation from 2010's assumed marginal generator (a combined cycle gas turbine [CCGT] power station) to a modelled energy mix in 2030 consistent with energy and climate policy and predicted demand reduction scenarios by that point. A grid-average emissions factor is projected by BEIS for 2040 and the marginal factor is assumed to converge with it by that date, interpolated between 2030 and 2040; both factors are then interpolated from 2040 to a national goal for carbon intensity of electricity generation in 2050 [Ref. 6.1.2].

6.1.4.4 BEIS's projected factors are for scope 2 emissions, and only include scope 3 insofar as the as-consumed factors allow for transmission and distribution losses. They do not include scope 3 supply chain emissions for the electricity generators, unlike the data for present-day carbon intensity of grid-supplied electricity.

- 6.1.4.5 It is acknowledged that the grid average annual carbon intensity changed significantly in recent years and is likely to continue to do so, due to changes in the mix of coal- and gas-fired generation, increased market share of renewables and nuclear, and use of interconnectors. The current and likely future baseline carbon intensity of marginal grid electricity generation is also acknowledged to vary with daily and seasonal cycles due short-term demand peaks (which may be satisfied by higher carbon intensity peaking plants) and with factors such as weather conditions (affecting renewable generation) and fuel prices. However, as the Proposed Development or K1 in the future baseline is expected to operate as a baseload generator, it is considered that the annual average emissions factors for the existing and future marginal sources published by BEIS are adequately representative without more detailed hourly or daily analysis.
- 6.1.4.6 As discussed in Chapter 6, the BEIS projections, while indicating a low carbon intensity of average and marginal electricity generation by 2045, do not necessarily exclude a (limited) continued presence of gas-fired generation in the electricity mix. Displacement of such a generation source by the Proposed Development’s electricity export is considered plausible and has been assessed as a scenario in Chapter 6. The emissions intensity of a marginal CCGT power station, stated by BEIS to be 0.3426 kgCO<sub>2</sub>e/kWh excluding transmission and distribution losses and other scope 3 emissions [Ref. 6.1.2], has been used.

### 6.1.5 Calculation outputs

- 6.1.5.1 Table 6.1.2 shows the current baseline GHG emissions from K1 operation (one year).
- 6.1.5.2 Table 6.1.3 shows GHG emissions in the future baseline, in the future with the Proposed Development, and the net change, over the Proposed Development’s assumed 25-year operating lifetime of 2021–2045. In Table 6.1.4 these results are expressed on a carbon intensity basis, i.e. per MWh of energy.

Gas supply and combustion	Gross GHG emissions	Marginal electricity generation	Displaced GHG emissions	Net GHG emissions	Net GHG emissions intensity
tCO <sub>2</sub> e/MWh	tCO <sub>2</sub> e	tCO <sub>2</sub> e/MWh	tCO <sub>2</sub> e	tCO <sub>2</sub> e	tCO <sub>2</sub> e/MWh
0.2356	495,216	0.2982	-16,299	478,916	0.2879

Table 6.1.2: Current baseline GHG emissions from K1 operation

Year	Emissions factors		Future baseline GHG emissions – K1			Proposed Development GHG emissions			Change		
	Marginal electricity generation	Gas supply and combustion	Gas combusted	Displaced grid electricity	Net emissions	Gas combusted	Displaced grid electricity	Net emissions	Total emissions reduction	Ratio of K4:K1	
	tCO <sub>2</sub> e/MWh	tCO <sub>2</sub> e/MWh	tCO <sub>2</sub> e	tCO <sub>2</sub> e	tCO <sub>2</sub> e	tCO <sub>2</sub> e	tCO <sub>2</sub> e	tCO <sub>2</sub> e	tCO <sub>2</sub> e		
1	2021	0.2486	0.2356	376,020	-13,591	362,429	343,294	-37,288	306,006	56,423	0.84
2	2022	0.2370	0.2356	376,020	-12,957	363,062	343,294	-35,550	307,745	55,318	0.85
3	2023	0.2248	0.2356	376,020	-12,289	363,731	343,294	-33,717	309,578	54,153	0.85
4	2024	0.2119	0.2356	376,020	-11,584	364,435	343,294	-31,783	311,511	52,924	0.85
5	2025	0.1983	0.2356	376,020	-10,841	365,178	343,294	-29,745	313,550	51,629	0.86
6	2026	0.1840	0.2356	376,020	-10,058	365,962	343,294	-27,595	315,700	50,262	0.86
7	2027	0.1689	0.2356	376,020	-9,231	366,788	343,294	-25,327	317,967	48,821	0.87
8	2028	0.1529	0.2356	376,020	-8,360	367,660	343,294	-22,936	320,358	47,302	0.87
9	2029	0.1361	0.2356	376,020	-7,441	368,579	343,294	-20,415	322,880	45,699	0.88
10	2030	0.1184	0.2356	376,020	-6,472	369,548	343,294	-17,756	325,539	44,009	0.88
11	2031	0.1081	0.2356	376,020	-5,909	370,110	343,294	-16,214	327,081	43,029	0.88
12	2032	0.0987	0.2356	376,020	-5,396	370,623	343,294	-14,805	328,489	42,134	0.89
13	2033	0.0901	0.2356	376,020	-4,928	371,092	343,294	-13,519	329,775	41,317	0.89
14	2034	0.0823	0.2356	376,020	-4,500	371,520	343,294	-12,345	330,949	40,571	0.89
15	2035	0.0752	0.2356	376,020	-4,109	371,911	343,294	-11,273	332,021	39,889	0.89
16	2036	0.0686	0.2356	376,020	-3,752	372,268	343,294	-10,294	333,001	39,267	0.89
17	2037	0.0627	0.2356	376,020	-3,426	372,594	343,294	-9,400	333,895	38,699	0.90
18	2038	0.0572	0.2356	376,020	-3,128	372,891	343,294	-8,583	334,711	38,180	0.90
19	2039	0.0523	0.2356	376,020	-2,857	373,163	343,294	-7,838	335,457	37,706	0.90
20	2040	0.0477	0.2356	376,020	-2,609	373,411	343,294	-7,157	336,137	37,274	0.90
21	2041	0.0455	0.2356	376,020	-2,486	373,534	343,294	-6,819	336,475	37,059	0.90
22	2042	0.0432	0.2356	376,020	-2,362	373,657	343,294	-6,482	336,813	36,844	0.90
23	2043	0.0410	0.2356	376,020	-2,239	373,780	343,294	-6,144	337,151	36,630	0.90
24	2044	0.0387	0.2356	376,020	-2,116	373,903	343,294	-5,806	337,488	36,415	0.90
25	2045	0.0365	0.2356	376,020	-1,993	374,026	343,294	-5,468	337,826	36,200	0.90
<b>Totals</b>	-	-	-	<b>9,400,490</b>	<b>-154,634</b>	<b>9,245,857</b>	<b>8,582,362</b>	<b>-424,260</b>	<b>8,158,102</b>	<b>1,087,755</b>	<b>0.88</b>

Table 6.1.3: Future baseline and Proposed Development GHG emissions

Year	Future baseline	Proposed Development	Change	Ratio of K4:K1
	tCO <sub>2</sub> e/MWh	tCO <sub>2</sub> e/MWh	tCO <sub>2</sub> e/MWh	
1 2021	0.2871	0.2254	-0.0617	0.79
2 2022	0.2876	0.2266	-0.0609	0.79
3 2023	0.2881	0.2280	-0.0601	0.79
4 2024	0.2886	0.2294	-0.0592	0.79
5 2025	0.2892	0.2309	-0.0583	0.80
6 2026	0.2899	0.2325	-0.0574	0.80
7 2027	0.2905	0.2342	-0.0563	0.81
8 2028	0.2912	0.2359	-0.0553	0.81
9 2029	0.2919	0.2378	-0.0541	0.81
10 2030	0.2927	0.2397	-0.0530	0.82
11 2031	0.2931	0.2409	-0.0523	0.82
12 2032	0.2935	0.2419	-0.0516	0.82
13 2033	0.2939	0.2429	-0.0511	0.83
14 2034	0.2943	0.2437	-0.0505	0.83
15 2035	0.2946	0.2445	-0.0501	0.83
16 2036	0.2949	0.2452	-0.0496	0.83
17 2037	0.2951	0.2459	-0.0492	0.83
18 2038	0.2953	0.2465	-0.0488	0.83
19 2039	0.2956	0.2470	-0.0485	0.84
20 2040	0.2958	0.2475	-0.0482	0.84
21 2041	0.2959	0.2478	-0.0481	0.84
22 2042	0.2960	0.2480	-0.0479	0.84
23 2043	0.2960	0.2483	-0.0478	0.84
24 2044	0.2961	0.2485	-0.0476	0.84
25 2045	0.2962	0.2488	-0.0475	0.84
<b>2021-2045</b>	<b>0.2929</b>	<b>0.2403</b>	<b>-0.0526</b>	<b>0.82</b>

Table 6.1.4: Future baseline and Proposed Development GHG emissions intensity



## References

- 6.1.1 BEIS and Defra (2017): *UK Government GHG Conversion Factors for Company Reporting v1.0*, [online] available at [https://www.gov.uk/government/uploads/system/uploads/attachment\\_data/file/635633/Conversion\\_factors\\_2017\\_-\\_Full\\_set\\_for\\_advanced\\_users\\_v02-00.xls](https://www.gov.uk/government/uploads/system/uploads/attachment_data/file/635633/Conversion_factors_2017_-_Full_set_for_advanced_users_v02-00.xls) [accessed 24 November 2017].
- 6.1.2 BEIS (2017): *Valuation of Energy Use and Greenhouse Gas: Supplementary guidance to the HM Treasury Green Book and supporting data tables and background papers*, [online] available at: <https://www.gov.uk/government/publications/valuation-of-energy-use-and-greenhouse-gas-emissions-for-appraisal> [accessed 24 November 2017].